

Gtech Pro K9

Model number: ATF303

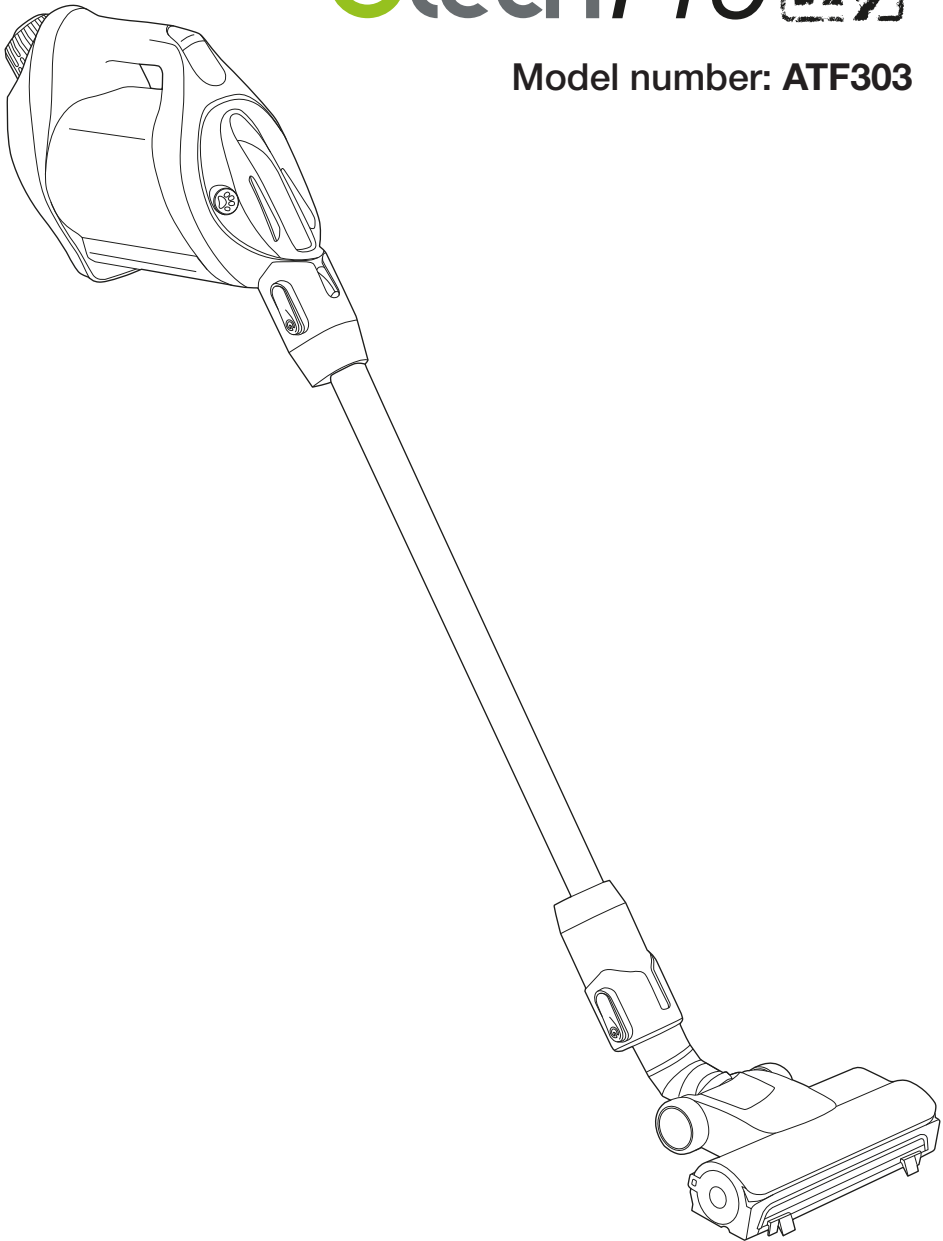

OPERATING MANUAL

IMPORTANT SAFEGUARDS:



IMPORTANT: READ ALL INSTRUCTIONS BEFORE USE. RETAIN INSTRUCTIONS FOR FUTURE REFERENCE.



Do not use in rain or leave outdoors whilst raining.



WARNING: Basic safety precautions should always be observed when using an electrical appliance, including the following to reduce the risk of fire, electrical shock, or injury:

Personal Safety:

- Store indoors in a dry place out of the reach of children.
- Always use responsibly. This appliance can be used by children aged from 8 years and above and persons with reduced physical, sensory or mental capabilities or lack of experience and knowledge if they have been given supervision or instruction concerning use of the appliance in a safe way and understand the hazards involved.
- Don't let children play with the appliance; supervise children using or maintaining the appliance.
- Use only manufacturer's recommended attachments as described in this manual; misuse or use of any accessory or attachment other than those recommended, may present a risk of personal injury.
- Take extra care when cleaning stairs.
- Keep the appliance and accessories away from hot surfaces.
- Do not block the appliances openings or hinder air flow; keep openings free of any objects including dust, lint, clothing, fingers (and all parts of the body).
- Particularly keep hair away from the brush bar and other moving parts, but also loose clothing, fingers and other body parts
- The Gtech Pro K9 does not stay upright without constant support. Between uses, lie flat on the floor in a suitable location so that it does not become a trip hazard or can be stepped on.

Electrical safety:

- Only use batteries and chargers supplied by Gtech.
- Never modify the charger in any way.
- The charger has been designed for a specific voltage. Always check that the mains voltage is the same as that stated on the rating plate.
- A charger that is suitable for one type of battery pack may create a risk of fire when used with another battery pack; never use the charger with another appliance or attempt to charge this product with another charger.
- Before use, check the charger cord for signs of damage or ageing. A damaged or entangled charger cord increases the risk of fire and electric shock.
- Do not abuse the charger cord.
- Never carry the charger by the cord.
- Do not pull the cord to disconnect from a socket; grasp the plug and pull to disconnect.
- Don't wrap the cord around the charger when storing.
- Keep the charger cord away from hot surfaces and sharp edges.
- The supply cord cannot be replaced. If the cord is damaged the charger should be discarded and replaced.
- Do not handle the charger or the appliance with wet hands.
- Do not store or charge the appliance outdoors.
- The charger must be removed from the socket before removing the battery, cleaning or maintaining the appliance.
- Ensure the appliance is off before connecting or disconnecting the accessories and motorised brush bar.

Battery safety:

- This appliance includes Li-Ion batteries; do not incinerate batteries or expose to high temperatures, as they may explode.
- Liquid ejected from the battery may cause irritation or burns.
- In an emergency situation contact professional help immediately!
- Leaks from the battery cells can occur under extreme conditions. Do not touch any liquid that leaks from the battery. If the liquid gets on the skin wash immediately with soap and water. If the liquid gets into the eyes, flush them immediately with clean water for a minimum of 10 minutes and seek medical attention. Wear gloves to handle the battery and dispose of immediately in accordance with local regulations.
- Shorting the battery terminals may cause burns or fire.
- When the battery pack is not in use, keep it away from paper clips, coins, keys, nails, screws or other small metal objects that could make a connection from one terminal to another.
- When you dispose of the appliance remove the battery and dispose of the battery safely in accordance with local regulations.

Service:

- **CAUTION** – To reduce the risk of injury from moving parts, remove battery before servicing.
- Before using the appliance and after any impact, check for signs of wear or damage and repair as necessary.
- Do not use the appliance if any part is damaged or defective.
- Repairs should be carried out by a service agent or a suitably qualified person in accordance with relevant safety regulations. Repairs by unqualified persons could be dangerous.
- The Gtech Pro K9 can be used for above floor cleaning & hard to reach places. Extra care should be taken when using the Gtech Pro K9 for above floor cleaning.

- Never modify the appliance in any way as this may increase the risk of personal injury.
- Only use replacement parts or accessories provided or recommended by Gtech.
- If appliance is not working as it should, has been dropped, damaged, left outdoors, or dropped into water, return it to a service centre.

Intended use:

- This appliance has been designed for domestic dry vacuum cleaning only.
- Do not pick up liquids or use on wet surfaces.
- Do not pick up anything that is flammable, burning or smoking.
- Use only as described in this manual.
- Don't use on concrete, tarmacadam or other rough surfaces.
- The brush bar may damage certain floor surfaces. Before vacuuming flooring, rugs or carpets, check the flooring manufacturer's recommended cleaning instructions.
- May damage delicate fabrics or upholstery. Care should be taken on loose-weave fabrics or where there are loose threads. If in doubt please test on an inconspicuous area first.
- The Gtech Pro K9 has a constantly rotating brush bar. Never leave the cleaning head in one spot for an extended period of time as this may damage the floor surface.

WARNING:

- **Do not use water, solvents, or polishes to clean the outside of the appliance; wipe clean with a dry cloth.**
- **Never immerse the unit in water and do not clean in a dish washer.**
- **Only use authentic Gtech bags, batteries, charger etc.**
- **Do not use without bag fitted.**
- **Never use the extension tube without a tool attached.**
- **For household use only.**

Thank you for choosing a Gtech Pro K9

"I started Gtech to create sensible, easy to use products, which do a great job. Your opinion is important to us and we will use your feedback to improve our products and services and let other people know what it's like to be part of the Gtech family."

Nick Grey – Inventor, Owner of Gtech

Make a note of your product serial number code for future reference. You can find this on the main unit by removing your battery.

_ _ _ _ _ ~
 _ _ _ _ _ ~
 _ _ _ _ _ ~
 _ _ _ _ _ ~

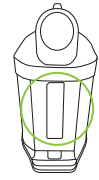

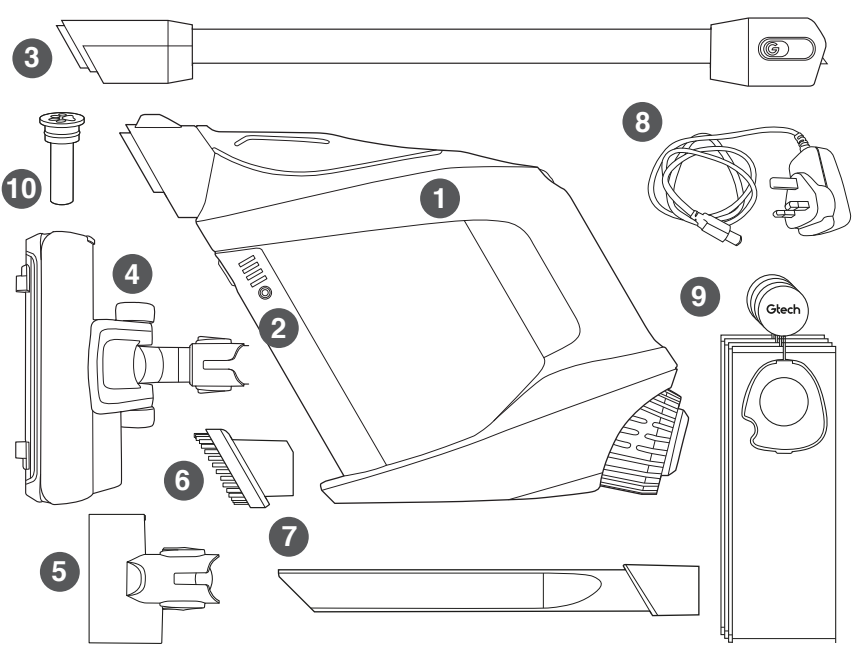

What's in the box

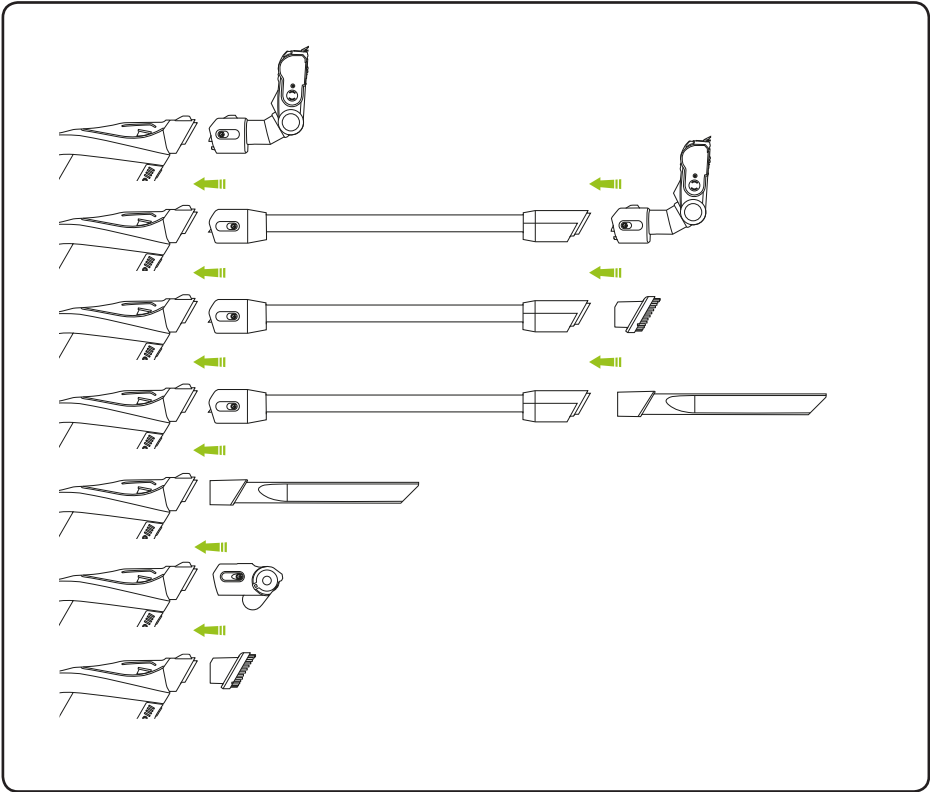

- 1** Main unit (1 bag fitted)
- 2** Battery (fitted)
- 3** Extension tube
- 4** Power floor head
- 5** Power brush
- 6** Dusting brush
- 7** Crevice tool
- 8** Charger
- 9** 4x spare bags (+1 in unit)
- 10** 5x spare scented cartridges (+1 in unit)

Tool configurations



Operation



Press the large button above the handle to turn the Gtech Pro K9 on and off.



The Gtech Pro K9 has 2 power settings: Max mode (higher suction power and shorter runtime) and Eco mode (lower suction power and longer runtime). Change modes by sliding the switch located in front of the on/off button. The Gtech Pro K9 will turn on in the mode it was last used.

Power floor head assembly

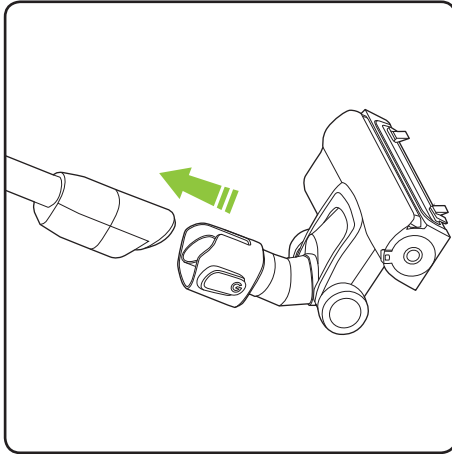

The power must be off while changing tools. Take the power floor head and attach it to the extension tube.



Attach the extension tube to the Gtech Pro K9.



Place your foot gently on the head of the vacuum and pull the body back towards you. You will hear a click.

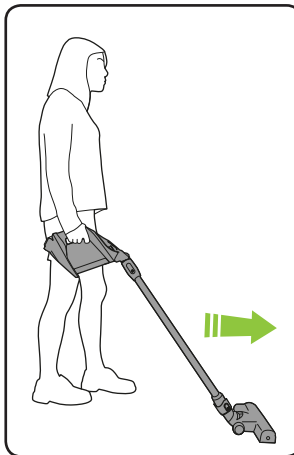

A forward motion will pick up larger pieces of debris.

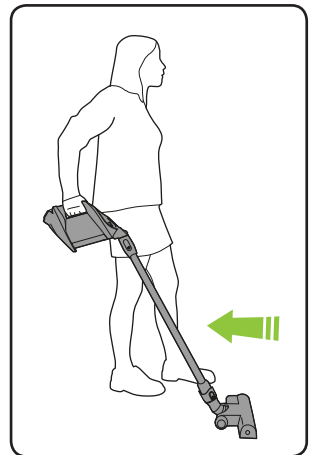

Pulling the vacuum back towards you activates the AirLOC and picks up fine particles.

Above the floor cleaning

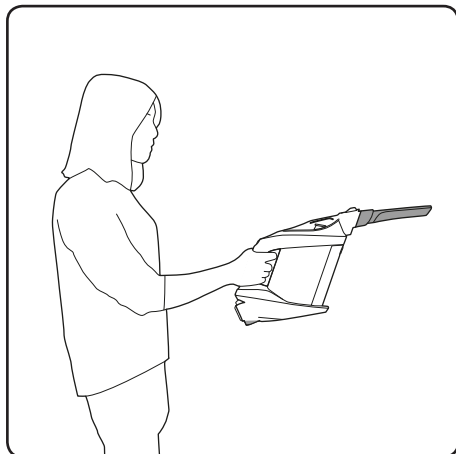

For above the floor cleaning you can fit the crevice tool or dusting brush for close-to work...

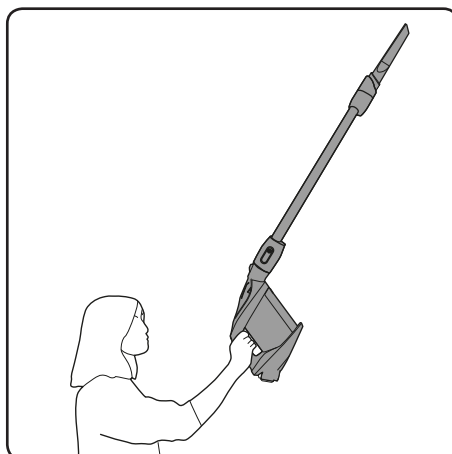

...or fit the extension tube with an accessory for high-up cleaning.

Removing and cleaning the brush bar

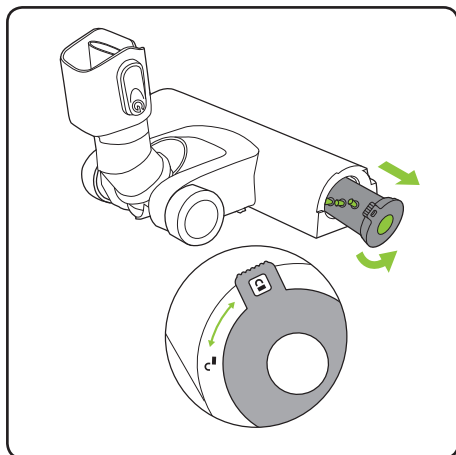

Before you remove the brush bar, you will need to remove the power floor head from the extension tube. Rotate the latch on the side of the powered floor head to the 'unlock' position and pull out the brush bar.

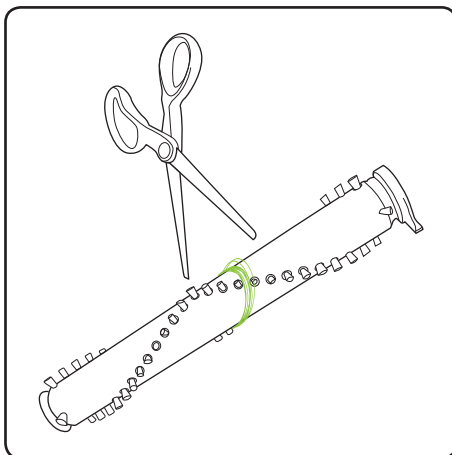

To remove hair from the brush bar, run an open pair of scissors down the groove to cut the hair, then pull it out. Never operate the power floor head without the brush bar in.

Power brush

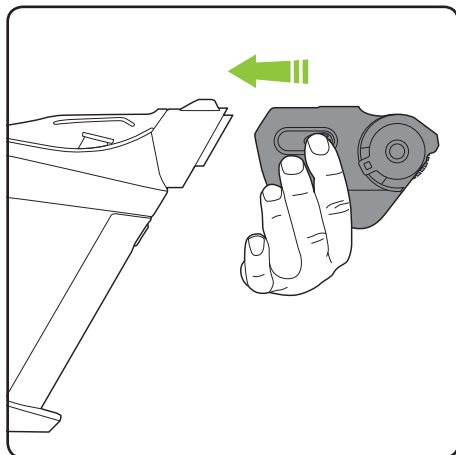

To attach the power brush slot it over the standard nozzle. The power must be off while changing nozzles. The power button will now power the brush as well as the suction.

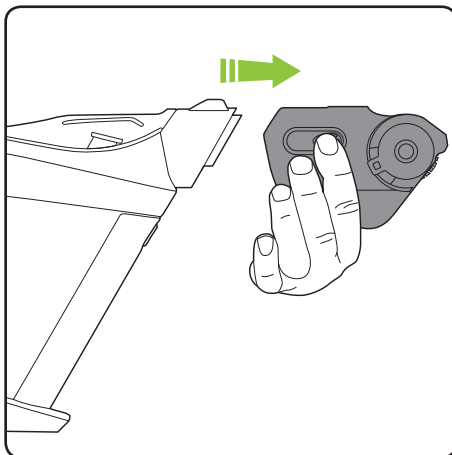

To remove the power brush, press the buttons on the sides of the attachment and pull it away from the main unit.

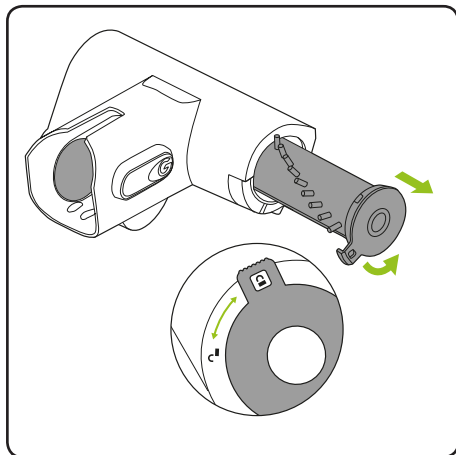

To clean the brush bar, first remove the power brush. Rotate the latch from the lock to the unlock position and pull out the brush bar.

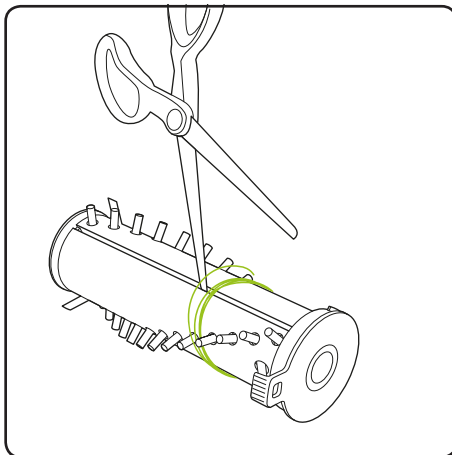

To remove hair from the brush bar, run an open pair of scissors down the groove to cut the hair, then pull it out. Never operate the power head without the brush bar in.

Installing scented cartridge

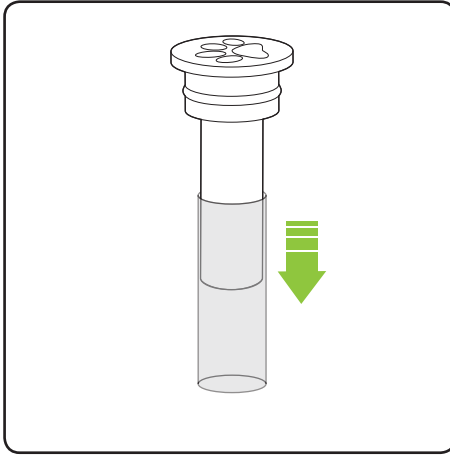

Remove the scented cartridge from its box then slide the plastic sleeve off.

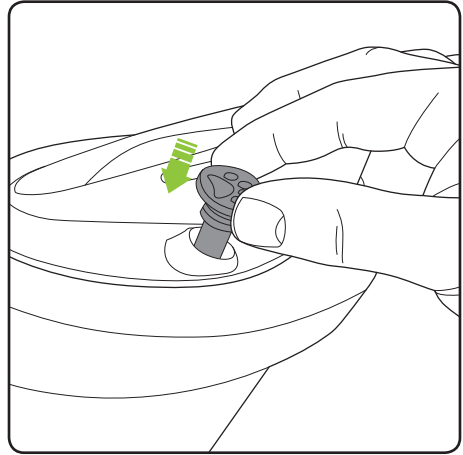

Slide scented cartridge into the opening on the right side of the lid.

Product has to have scented cartridges fitted to function.

Removing attachments

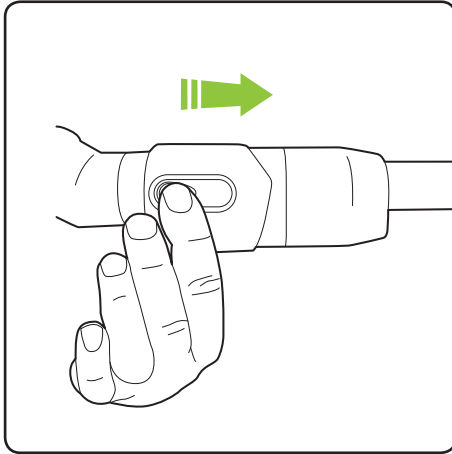

To remove the extension tube and floor head, press the buttons on the sides of the attachments and pull it away from the unit.

LED Headlights

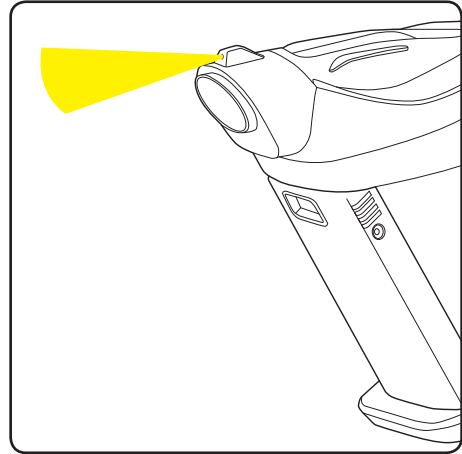

There is a headlight on top of the Gtech Pro K9 to illuminate the area being cleaned.

State of Charge



The battery state of charge indicator shows how much charge the Gtech Pro K9 has. As you use the product, the green lights will turn off in a downwards direction.

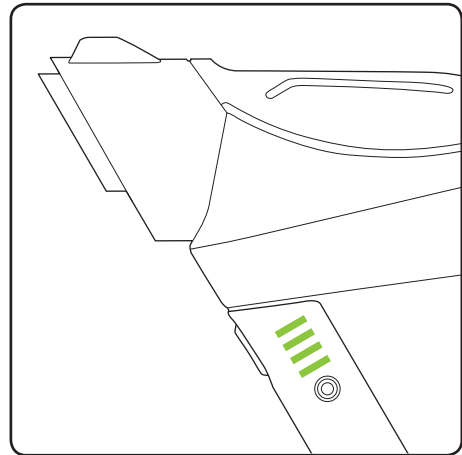

While the battery is on charge, the LEDs will pulsate and in turn illuminate. When the battery is fully charged all of the LEDs will be solid green.

Battery charging



When a single green light flashes, recharge the battery.

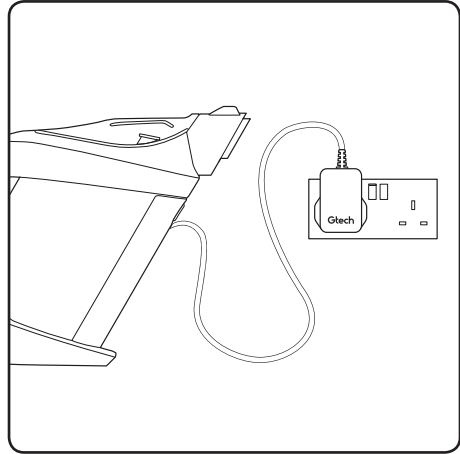

Plug the charger in and connect it to the charging port at the side of the battery.



After 4 hours the LEDs will show solid green and charging is complete.

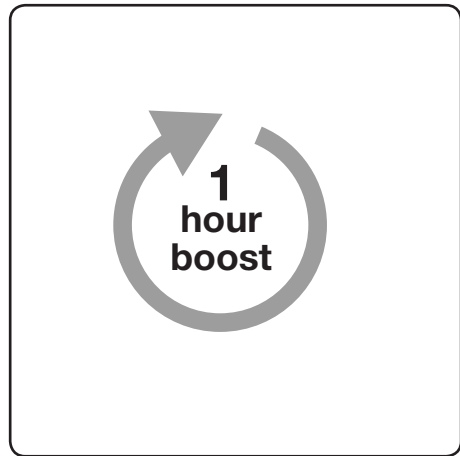

It is OK to charge for 1 hour for a burst of cleaning.

Removing the battery

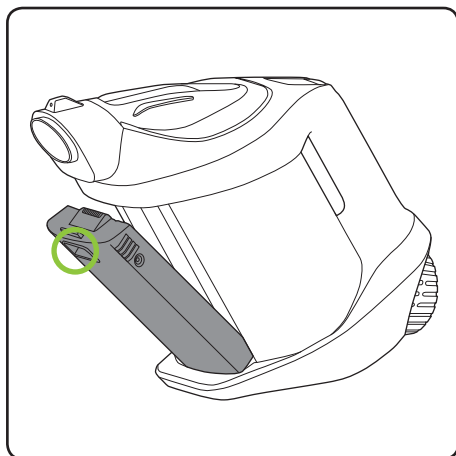

Pull the latch at the top of the battery to remove.

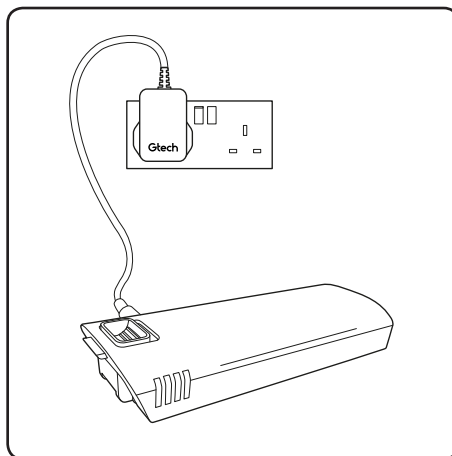

The battery can be charged on or off the main unit.

Refitting the battery



To replace the battery, slot it into the front of the Gtech Pro K9 from the bottom first, with the latch facing outwards.

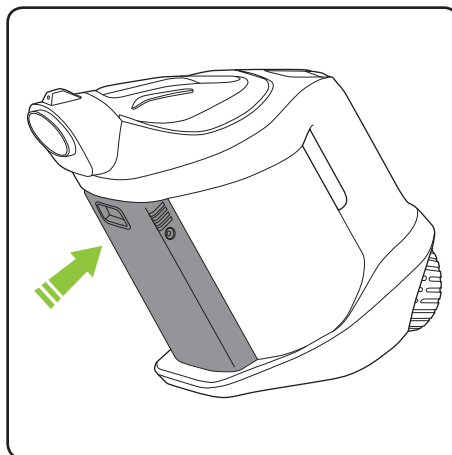

Push the battery into the slot until it clicks into place. If you want to buy a spare battery go to www.gtech.co.uk or call **01905 345891**.

Bag Installation

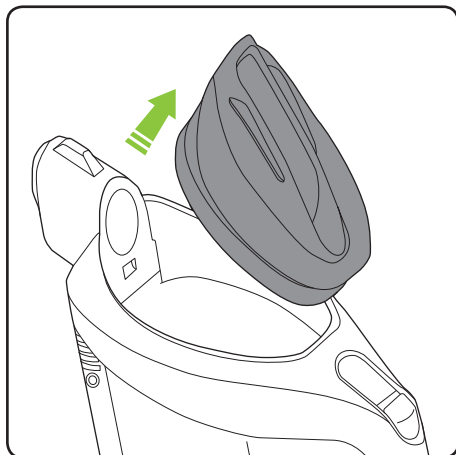

Remove the lid by pulling gently upwards.

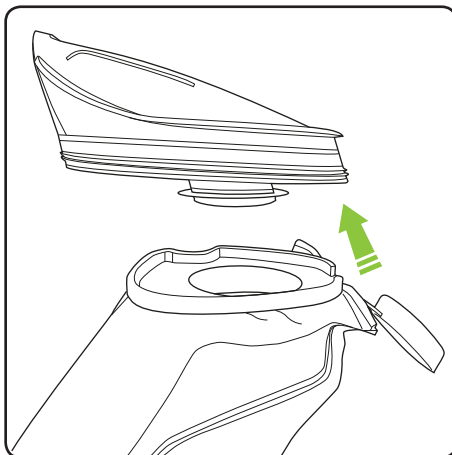

Fit the bag collar onto the tube underneath the lid and push it up firmly.

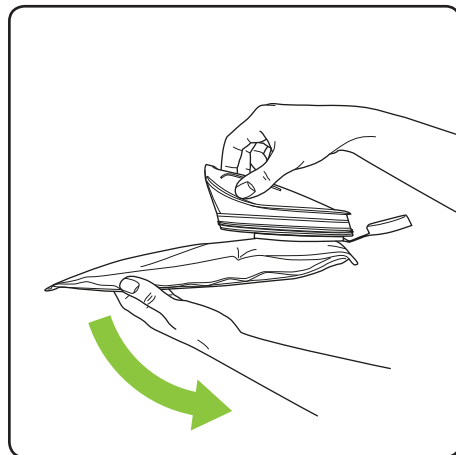

New bags have a tendency to sit flat when first attached. Pull the bag down to sit vertically.

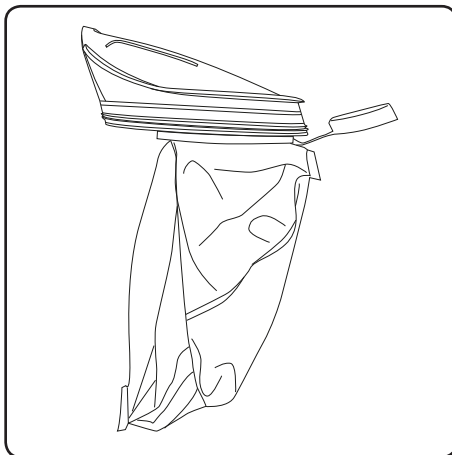

To get maximum efficiency from the bag it is important to expand the bag before insertion.

Do not use the vacuum without a bag; it may damage the motor and will invalidate your warranty.

Bag Removal

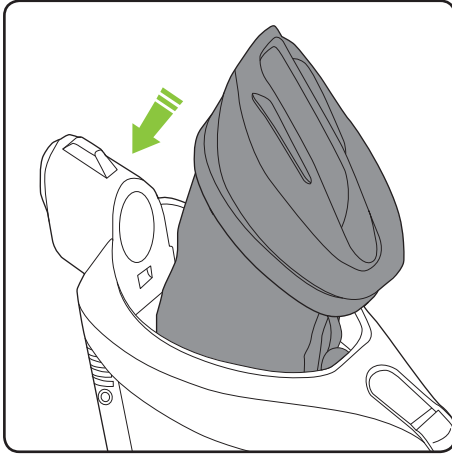

Once the bag is attached and straightened, place the lid back onto the main body making sure the bag cap is also inserted.

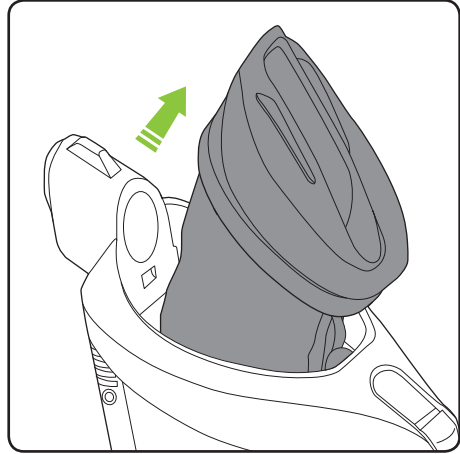

When the bag is full, lift the lid and remove from the Gtech Pro K9 with bag attached.

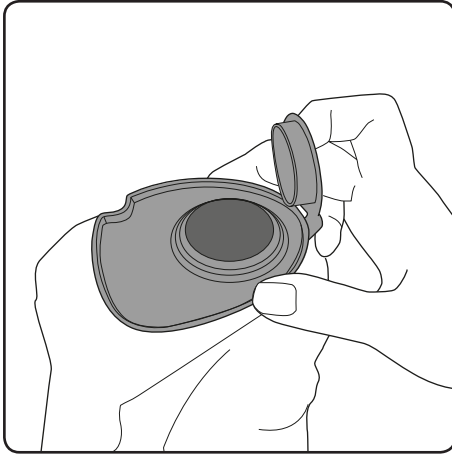

Carefully remove the bag from the Gtech Pro K9 lid to avoid squashing contents. Insert the bag cap to secure contents.

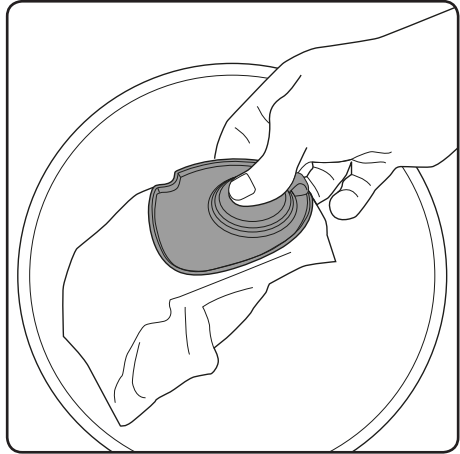

Dispose of the bag and replace with a new one.
(You can get more bags at www.gtech.co.uk)
Do not reuse bags as this could damage and reduce the performance of the Gtech Pro K9.

If the suction is low when the bag is empty and a new bag is fitted you have a blockage.

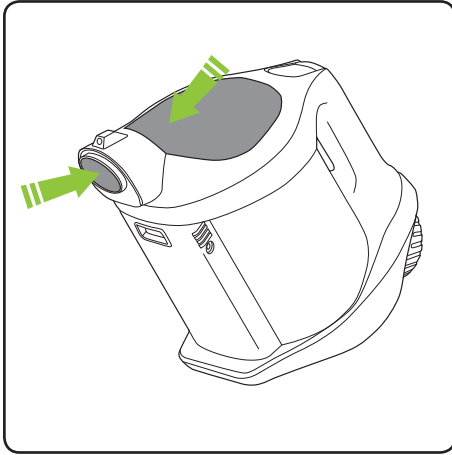

Remove the battery and lid and look through the nozzle. Remove any blockages.

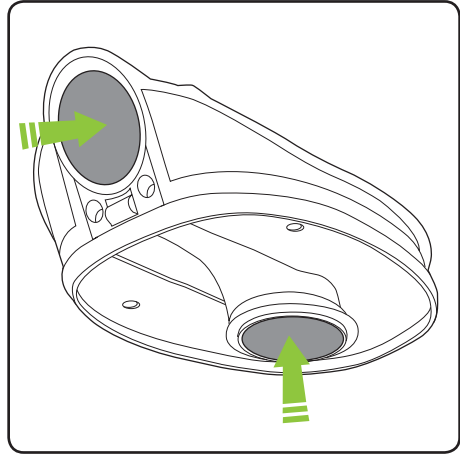

Remove the bag from the lid. Check for any blockages in the lid. Remove any blockages.

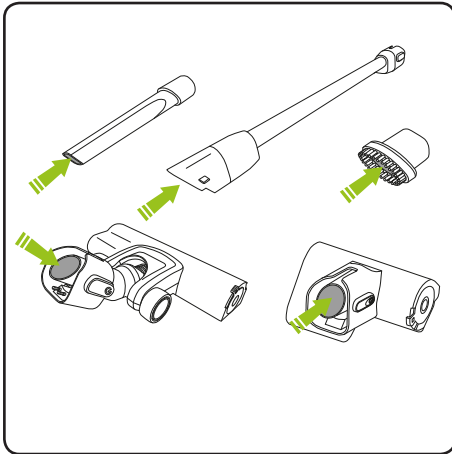

The tools can block too, sometimes.

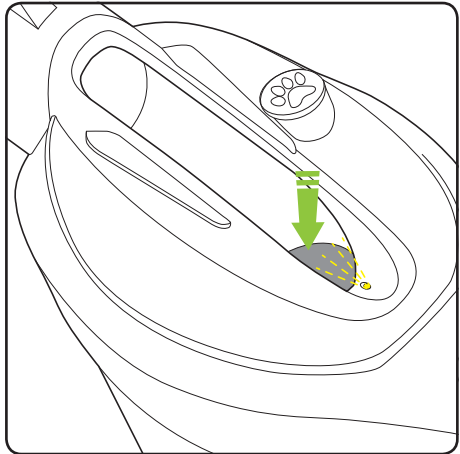

A light above the window on the top of the lid allows visibility into the bag to indicate when the bag is full or if there is a blockage.

Product Care

Your Gtech Pro K9 doesn't need much maintenance: keep it clean, check for blockages, remove hair from the brush bar and charge the battery. Wipe it with a dry cloth if it gets dirty. Never wash it with liquid, run it under a tap or use it without the bag. Regularly check if the bag is full.

Troubleshooting

Gtech Pro K9 is not cleaning well	<ol style="list-style-type: none"> 1. Change the bag 2. Check for blockages 3. Remove hair from brush bar
Gtech Pro K9 has stopped or won't work	<ol style="list-style-type: none"> 1. Charge the battery (check the socket works and is turned on) 2. It might be blocked – see page 16
4 Red lights displayed on battery	<ol style="list-style-type: none"> 1. Brush bar jammed. 2. Turn off Gtech Pro K9, remove the battery and clear the blockage.

Product Support

If these initial tips don't solve your problem, we have various other ways to help.

Visit: www.gtech.co.uk/support



Online



Live chat support



support@gtech.co.uk



How to Videos

GTECH PRO K9 TECHNICAL SPECIFICATION

Battery model	109A0015
Battery	22V 2000mAh Li-Ion
Charging period	4 hours
Battery charger output	27V DC 500mA
Weight (with standard nozzle)	2.4kg

WARRANTY – REGISTRATION

Visit www.gtech.co.uk/warrantyregistration to register your product to ensure that we have all the information required to provide you with quick and efficient support.

You will need your product's serial code.



If you purchased directly from Gtech your details are already registered and your 2 year warranty will start automatically.

If you purchased from an authorised Gtech retailer, please register your warranty within 3 months and you will need to provide proof of purchase to support any claim against your warranty.

WARRANTY – TERMS AND CONDITIONS

If your Gtech Pro K9 breaks, don't worry, we're here to help. Go to www.gtech.co.uk or call **01905 345 891** for assistance.

The warranty on your product is 2 years from date of purchase.

WHAT ISN'T COVERED

Gtech does not guarantee the repair or replacement of a product as a result of:

- Normal wear and tear (e.g. bags)
- Accidental damage, faults caused by negligent use or care, misuse, neglect, careless operation or handling of the vacuum cleaner which is not in accordance with Gtech Pro K9 operating manual.
- Blockages - please refer to the Gtech Pro K9 operating manual for details of how to unblock your vacuum cleaner.
- Use of the vacuum cleaner for anything other than the normal domestic household purposes.
- Use of parts and accessories which are not Gtech genuine components.
- Faulty installation (except where installed by Gtech)
- Repairs or alterations carried out by parties other than Gtech or its authorised agents.
- If you are in doubt as to what is covered by your guarantee, please call 01905 345 891.

SUMMARY

- The guarantee becomes effective at the date of purchase (or the date of delivery if this is later).
- You must provide proof of delivery/purchase before any work can be carried out on the vacuum cleaner. Without this proof, any work carried out will be chargeable. Please keep your receipt or delivery note.
- All work will be carried out by Gtech or its authorised agents.
- Any parts which are replaced will become the property of Gtech.
- The repair or replacement of your vacuum cleaner is under guarantee and will not extend the period of guarantee.
- The guarantee provides benefits which are additional to and do not affect your statutory right as a consumer.

The  symbol indicates that this product is covered by legislation for waste electrical and electronic products (EN2002/96/EC)

When the vacuum has reached the end of its life, it and the Li-Ion battery it contains should not be disposed of with general household waste. The battery should be removed from the vacuum and both should be disposed of properly at a recognised recycling facility.

FOR HOUSEHOLD USE ONLY

Call your local council, via amenity site, or recycling centre for information on the disposal and recycling of electrical products. Alternatively visit www.recycle-more.co.uk for advice on recycling and to find your nearest recycling facilities.





Grey Technology Limited

Brindley Road, Warndon, Worcester WR4 9FB

email: support@gtech.co.uk

telephone: 01905 345891

www.gtech.co.uk

OPN03237